

HOUSING + STRAIGHT FEMALE PLUG

CRIMP TYPE 2.6/50S CABLE PACK500

R197.114.D00

Series : **SMB**
CARLOCK

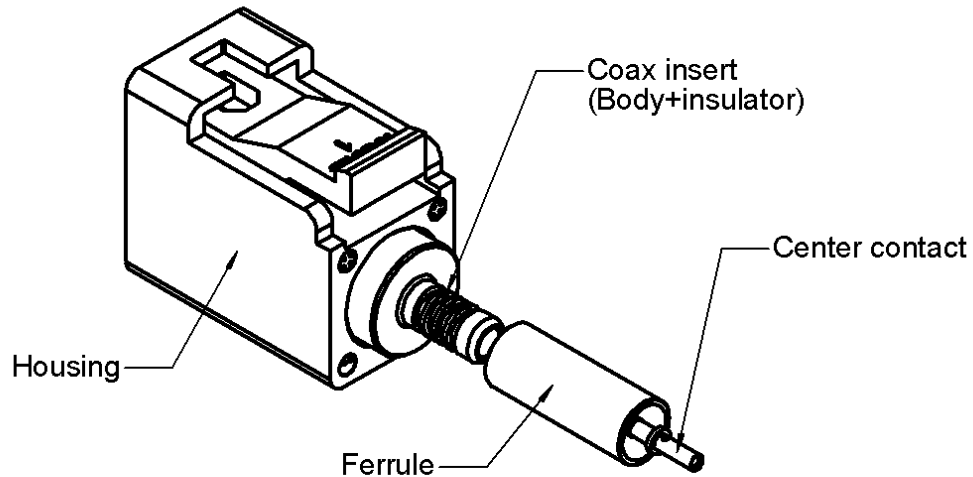
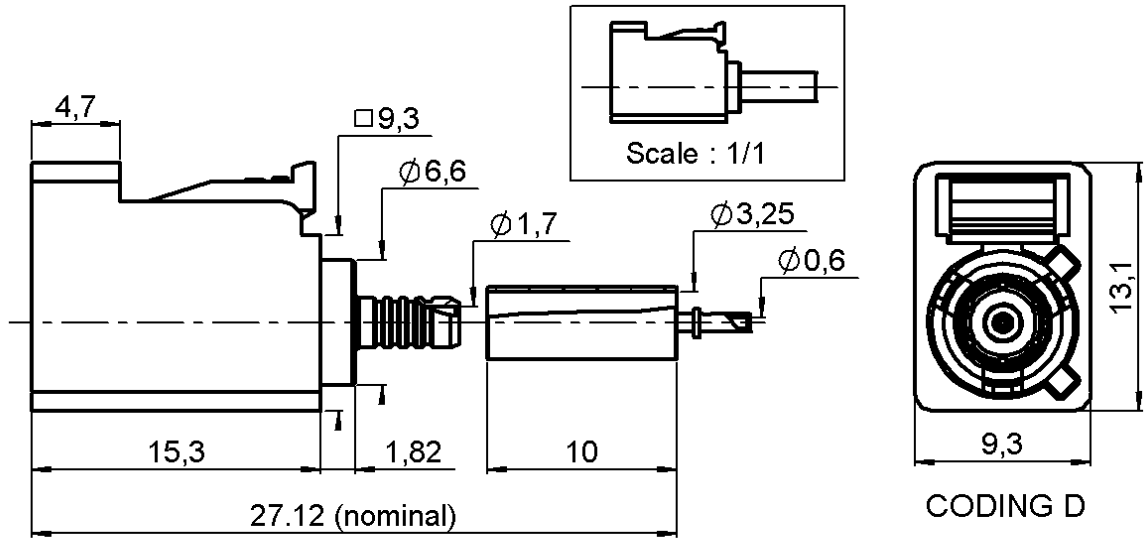

All dimensions are in mm.



COMPONENTS	MATERIALS	PLATINGS (µm)	
BODY	BRONZE	NICKEL 2	
CENTER CONTACT	BRONZE	GOLD 0.8 OVER NICKEL 2	
OUTER CONTACT	-	-	
INSULATOR	PTFE		
GASKET	-		
OTHERS PARTS	BRASS	NICKEL 2	
HOUSING	PA6.6 GF13 (POLYAMIDE)	UL CLASSIFICATION	COLOR
		UL 94 V-2	VIOLET RAL 4004

Issue : 0636 C

In the effort to improve our products, we reserve the right to make changes judged to be necessary.



HOUSING + STRAIGHT FEMALE PLUG

CRIMP TYPE 2.6/50S CABLE PACK500

R197.114.D00

Series : **SMB**
CARLOCK

PACKAGING

Standard	Unit	Other
500	'W' option	Contact us

SPECIFICATION

SAE/USCAR-17 Rev.1 (October 2002)
SAE/USCAR-2 Rev.3 (February 2001)
SAE/USCAR-18 Rev.2 (January 2003)

ELECTRICAL CHARACTERISTICS

Impedance	50	Ω
Frequency	0-4	GHz
VSWR	1.20** + 0,0000	x F(GHz) Maxi
Insertion loss	0.05	\sqrt{F} (GHz) dB Maxi
RF leakage	-45	- F(GHz)) dB Maxi
Voltage rating	335	Veff Maxi
Dielectric withstanding voltage	1000	Veff mini
Insulation resistance	1000	M Ω mini

CABLE ASSEMBLY

Stripping	a	b	c	d	e	f
mm	2,40	5,50	9,40	0,00	7,00	0,00

Assembly instruction : **Pages 3 & 4**

Recommended cable(s)
RG 174
RG 316

Characteristics indicated on this data sheet are those that can be achieved with the highest performance cable. Intrinsic limitations of the cable may diminish the performance of the assembly

Cable retention

- pull off	RG174 JUDD CABLE	110N mini
	RG316	110N mini
	RG174	65*N mini
- torque	NA	N.cm

MECHANICAL CHARACTERISTICS

Center contact retention		
Axial force – Mating end	10	N mini
Axial force – Opposite end	10	N mini
Torque	NA	N.cm mini

TOOLING

Part Number	Description	Hexagon
.	.	.
R282.293.000	CRIMPING TOOL M22520/5-01	
R282.235.915	CRIMPING DIES	Hex 3.25 Square 0.72
R282.271.000	CRIMPING TOOL	Hex 3.25 Square 0.72
R282.281.000	CRIMPING TOOL	2x4pts 3pos
R282.967.034	POSITIONER FOR TOOL R282 281	

Recommended torque		
Mating	NA	N.cm
Panel nut	NA	N.cm
Clamp nut	NA	N.cm
A/F clamp nut	0,0000	mm
Mating life	100	Cycles mini
Weight	3,1000	g

ENVIRONMENTAL

Operating temperature	-40/+110*	$^{\circ}$ C
Hermetic seal	NA	Atm.cm3/s
Panel leakage	NA	

OTHERS CHARACTERISTICS

* Depends on the cable used
** VSWR : 1.20 maxi at 4 GHZ

Issue : **0636 C**

In the effort to improve our products, we reserve the right to make changes judged to be necessary.





HOUSING + STRAIGHT FEMALE PLUG

R197.114.D00

CRIMP TYPE 2.6/50S CABLE PACK500

Series : SMB
CARLOCK

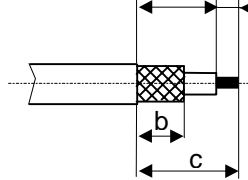
Recommended mounting procedure for RG174 cable

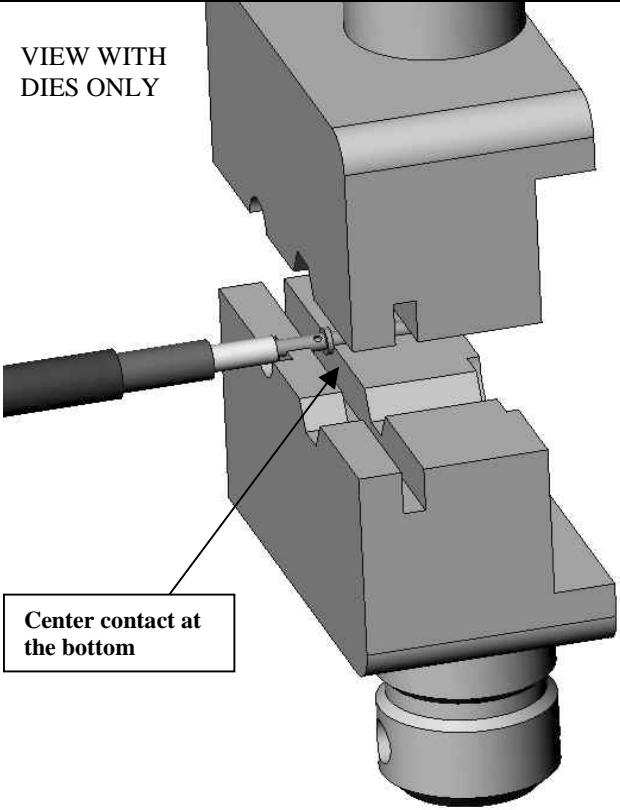
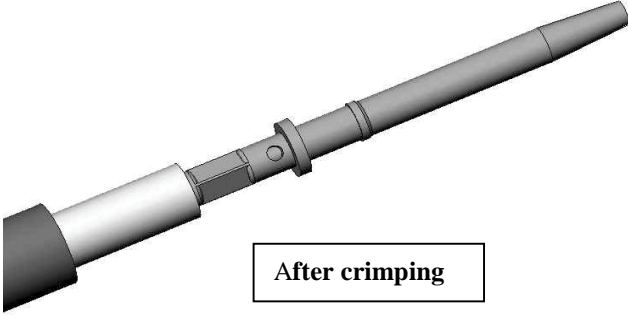
	
<p>1</p> <ul style="list-style-type: none"> • Slide the ferrule onto the cable • Strip the cable 	
<p>2</p> <ul style="list-style-type: none"> • Slide the centre contact on until it bottoms against the cable dielectric • Crimp the centre contact with crimping tool R282.271.000 (square 0.72) or R282.293.000 (M22520/5-01) + dies R282.235.915 (square 0.72) or R282.281.000 (M22520/2-01) (3 position) (2x4pts) with positioner R282.967.034. 	<p>VIEW WITH DIES ONLY</p>  <p>Center contact at the bottom</p>  <p>After crimping</p>

Issue : 0636 C

In the effort to improve our products, we reserve the right to make changes judged to be necessary.



HOUSING + STRAIGHT FEMALE PLUG

CRIMP TYPE 2.6/50S CABLE PACK500

R197.114.D00

Series : SMB
CARLOCK

Recommended mounting procedure for RG174 cable

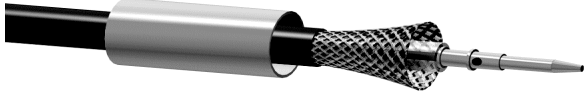
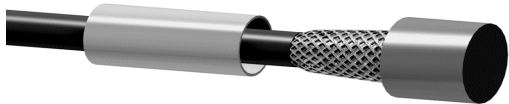
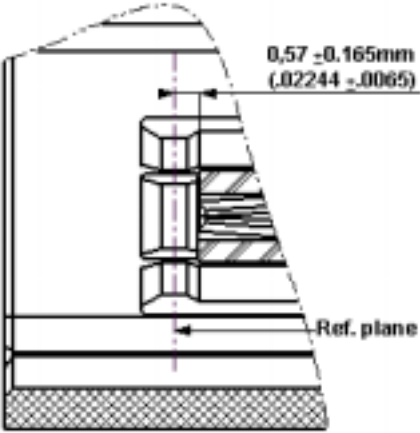
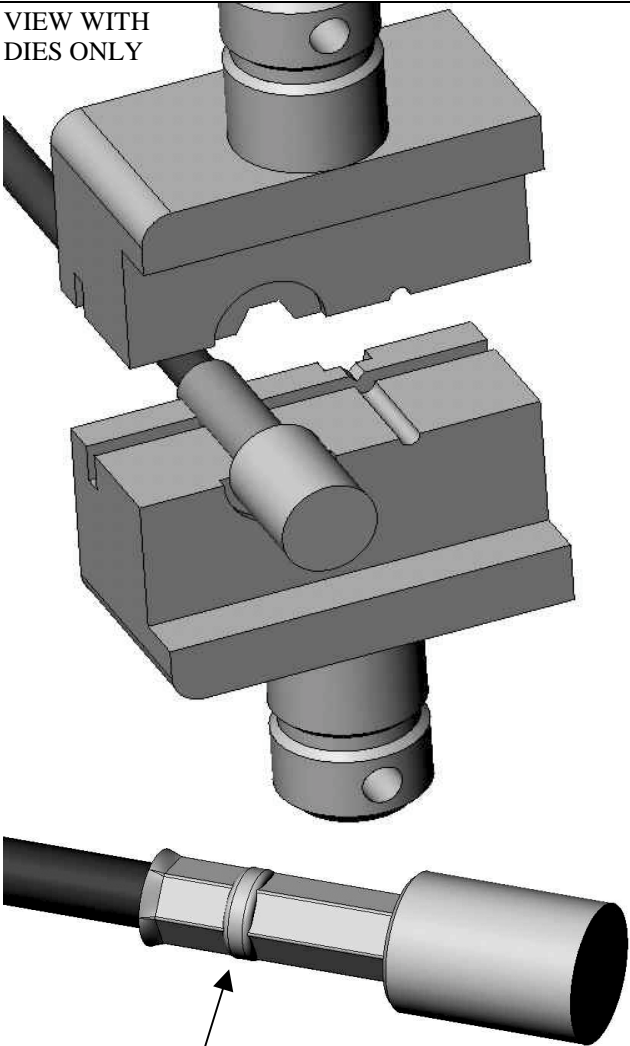
<p>3</p> <ul style="list-style-type: none"> • Fan the braid 	
<p>4</p> <ul style="list-style-type: none"> • Slide the cable into the body until it bottoms against insulator 	
<p>5</p> <ul style="list-style-type: none"> • Slide the ferrule over the braid • Crimp the ferrule as shown on this picture with crimping tool R282.293.000 (M22520/5-01) + dies R282.235.915 (Double crimping Hex 3.25) • Check the position of the center contact between the top of the center contact and the SMB ref. plane : 0.57 ± 0.165 	<p>VIEW WITH DIES ONLY</p>  <p>Right tool orientation : after crimping the bump must be closer to the cable than to the body</p>

Issue : 0636 C

In the effort to improve our products, we reserve the right to make changes judged to be necessary.

